

HXF SERIES, LOW PROFILE FLUOROPOLYMER (PTFE) HEATERS							
WATTS	VOLTS	HOT ZONE In./(mm)	OVERALL LENGTH In./(mm)	DIA. In./(mm)	MAX. COLD ZONE In./(mm)	MODEL NUMBER	SHIP WGT. Lbs./(kg)
500	120	6	14	5	36	HXF.5105-14- <b>**</b>	6
	240	(155)	(355)	(125)	(915)	HXF.5205-14- <b>**</b>	(2.5)
1000	120	7	14	6	36	HXF1106-14- <b>**</b>	7
	240	(180)	(355)	(155)	(915)	HXF1206-14- <b>**</b>	(3.5)
2000	120	9	17	8	35	HXF2108-17- <b>**</b>	8
	240	(230)	(430)	(205)	(890)	HXF2208-17- <b>**</b>	(4)
3000	480					HXF2408-17- <b>**</b>	
	240	10	23	9	35	HXF3209-23- <b>**</b>	13
4000	480	(255)	(585)	(230)	(890)	HXF3409-23- <b>**</b>	(6)
	240	12	29	11	35	HXF4211-29- <b>**</b>	15
5000	480	(305)	(735)	(280)	(890)	HXF4411-29- <b>**</b>	(7)
	240	13	35	12	31	HXF5212-35- <b>**</b>	18
6000	480	(330)	(890)	(305)	(790)	HXF5412-35- <b>**</b>	(8)
	240	14	40	13	25	HXF6213-40- <b>**</b>	22
	480	(355)	(1015)	(330)	(635)	HXF6413-40- <b>**</b>	(10)

Single phase only. This configuration is not recommended for electroless chemistry or phosphoric acid.

## Product Features and Benefits:

- ◆ **SUPERIOR CHEMICAL RESISTANCE:** Inert to most aqueous acid, alkaline, anodizing and pickling solutions up to 212°F (100°C).
- ◆ **RUGGED CONSTRUCTION:** Heavy wall fluoropolymer (PTFE) covered stainless steel element reduces permeation and eliminates the need for gas purge systems. Guaranteed 100% pinhole free.
- ◆ **OUTSTANDING PERFORMANCE:** Low watt density design (10 watts/square inch, 1.5w/cm<sup>2</sup>) for long service life. Flat, low profile design saves space in the tank. (This configuration not recommended for electroless chemistries or phosphoric acid).
- ◆ **CORROSION RESISTANT HEAD:** Vapor tight, flame retardant polypropylene terminal enclosure with 3-foot (.9m) flexible PVC liquid tight conduit.
- ◆ **SAFETY FEATURES:**
  - Grounded internal metal element.
  - Thermal protector built in. Replaceable PT-I fuse standard for solutions up to 190°F (88°C).
  - Non-floating construction.
- ◆ **CERTIFICATIONS:** UL, CSA, and CE.
- ◆ **SIZES:** 500 watts to 6,000 watts.
- ◆ **VOLTAGES:** 120, 240 or 480 volts. 208, 380, 415, 600 and other voltages available. Single phase only.
- ◆ **OPTIONS AVAILABLE** (consult factory):
  - Replaceable thermal protectors:
    - PT-IM: for solutions from 190°F (88°C) to 220°F (104°C).
  - Resettable thermal protectors:
    - PT-II: bi-metal switch for solutions up to 190°F (88°C).
    - PT-III: type-J thermocouple for solutions from 190°F (88°C) to 210°F (99°C).
    - PIII: type-J thermocouple for solutions from 210°F (99°C) to 250°F (121°C).
  - Longer vertical lengths (cold zones).
  - Polypropylene guards: recommended for applications up to 180°F (82°C).
  - Fluoropolymer (PTFE) guards: recommended for chromic acid or solutions over 180°F (82°C).
  - Special configurations.
  - Longer wire and conduit lengths.
  - Flexible continuous fluoropolymer leads (PIII protector only).
  - Lower watt densities for highly viscous solutions and technical acids.
  - Temperature and level controls sized to match the heater.

**FLOW FACTOR**

24050 COMMERCE PARK RD  
CLEVELAND, OHIO 44122  
866-360-9830  
www.flowfactor.com

## DIMENSIONS

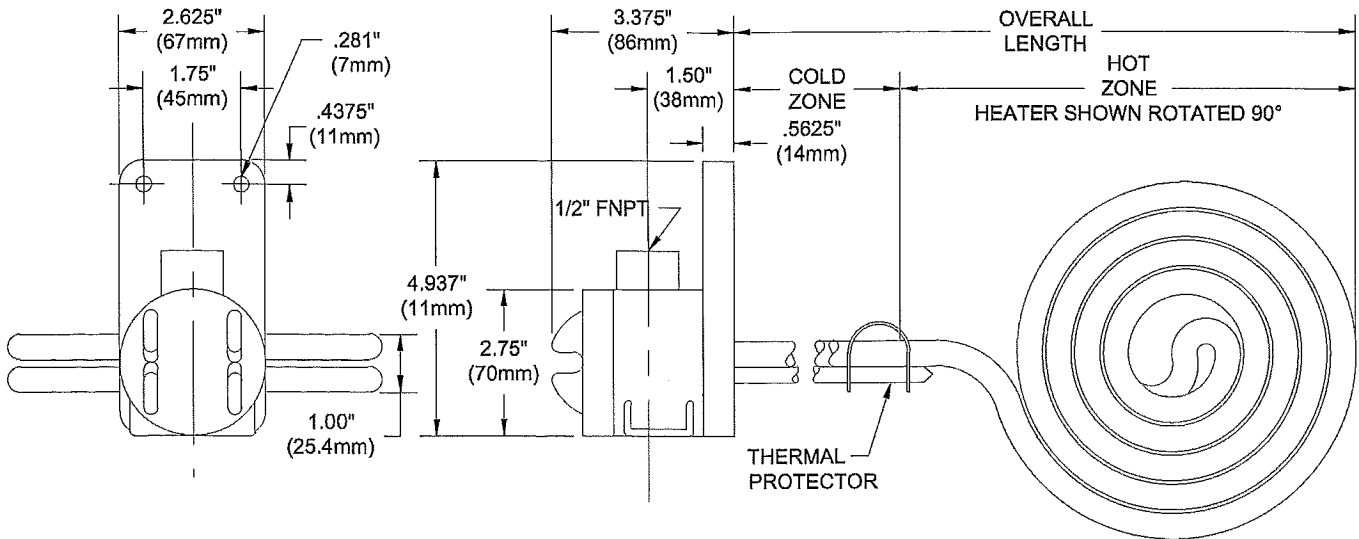

## LOW PROFILE FLUOROPOLYMER (PTFE) HEATER

Series	Wattage	Voltage	Diameter	Overall Length	Options	Type of Fuse	Wire and Conduit Length																
	.5 = 500 1 = 1000 2 = 2000 3 = 3000 4 = 4000 5 = 5000 6 = 6000	1 = 120 2 = 240 4 = 480 -208- = 208 -277- = 277 -380- = 380 -415- = 415 -600- = 600	05 = .5kW 06 = 1kW 08 = 2W 09 = 3kW 11 = 4kW 12 = 5kW 13 = 6kW	-14 = .5kW -14 = 1kW -17 = 2kW -23 = 3kW -29 = 4kW -35 = 5kW -40 = 6kW specify custom lengths, not to exceed tank depth			no designator = 36" length standard specify variations from standard Ex: -X84 = 84"																
	HXF = PTFE sheathed HSF = 304 stainless steel																						
	X = any special configuration not called out in the part number (specify in clear text) C = complete with guard																						
						<table border="1" style="width: 100%; border-collapse: collapse;"> <thead> <tr> <th colspan="2" style="text-align: center;">Replaceable Fuse</th> </tr> </thead> <tbody> <tr> <td style="width: 50%;">-PT-I (std)</td> <td>for solutions up to 190°F</td> </tr> <tr> <td>-PT-IM</td> <td>for 190° - 220°F solutions</td> </tr> <tr> <th colspan="2" style="text-align: center;">Resettable Fuse</th> </tr> <tr> <td colspan="2" style="text-align: center;">(additional control components required)</td> </tr> <tr> <td>-PT-II</td> <td>for solutions up to 190°F</td> </tr> <tr> <td>-PT-III</td> <td>for 190° - 210°F solutions</td> </tr> <tr> <td>-PIII</td> <td>for 210° - 250°F solutions</td> </tr> </tbody> </table>		Replaceable Fuse		-PT-I (std)	for solutions up to 190°F	-PT-IM	for 190° - 220°F solutions	Resettable Fuse		(additional control components required)		-PT-II	for solutions up to 190°F	-PT-III	for 190° - 210°F solutions	-PIII	for 210° - 250°F solutions
Replaceable Fuse																							
-PT-I (std)	for solutions up to 190°F																						
-PT-IM	for 190° - 220°F solutions																						
Resettable Fuse																							
(additional control components required)																							
-PT-II	for solutions up to 190°F																						
-PT-III	for 190° - 210°F solutions																						
-PIII	for 210° - 250°F solutions																						

### ORDERING EXAMPLE:

HXF5412-35-PT-I-X50

Flat fluoropolymer heater, 5000 watts, 480 volt, single phase, 12" diameter hot zone, 35" overall length, PT-I thermal fuse, 50" wire and conduit

**PROCESS  
TECHNOLOGY**

*FLOW FACTOR*

24050 COMMERCE PARK RD  
CLEVELAND, OHIO 44122  
866-360-9830  
www.flowfactor.com