



Models TEC-410 & TEC-910

Model TEC-410 1/4 DIN & Model TEC-910 1/16 DIN High Limit Temperature Controls



**FM Approved
High Limit
Control with
External Reset!**



Common Design Features

- * High Limit Control protects personnel, equipment and materials from over-temperature process conditions
- * Universal programmable sensor input
- * Versatile – 4 types of outputs available
- * Highly accurate universal input with 18 bit analog to digital converter
- * FM approved for electric & gas heat systems
- * Bright 0.40" (10 mm) red LED process display
- * Short panel depth required
- * Output 2 can be programmed as output or input

TEC-410 Design Features

- * Universal input power – 90-250 VAC or 11-26 VAC/VDC
- * Event input for remote reset
- * Two programmable outputs
- * Optional RS-485 or RS-232 communications interface
- * Optional retransmission
- * Optional NEMA 4X/IP65 front face

TEC-910 Design Features

- * Universal input power – 90-264 VAC or 11-26 VAC/VDC
- * Optional event input for remote reset
- * Optional RS-485 communications interface
- * Output 2 can be programmed as output or input

List Prices Starting at
\$293.55 (410) & \$185.40 (910)
Quantity Discounts Available!



Ordering Code:

TEC-410-

TEC-910-

Power Input BOX 1

- 4 = 90-250 VAC (TEC-410)
90-264 VAC (TEC-910)
- 5 = 11-26 VAC / VDC

Signal Input – Universal, can be programmed in the field BOX 2

- 1 = Input 1 – Universal input (factory default = TC type J)
Thermocouple: J, K, T, E, B, R, S, N, L, C, P
RTD: PT100 DIN, PT100 JIS
mV: 0 to 60
- 2 = DC Voltage: 0-1
- 3 = DC Voltage: 0-10
- 4 = DC Current: 0-20 mA
- 5 = DC Voltage: 0-5 (TEC-410 only)
- 9 = Other

Output 1 BOX 3

- 1 = Relay: 2A / 240 VAC, Form C
- 2 = Pulse DC for SSR drive: 5 VDC (30 mA max)
- 6 = Triac-SSR output 1A / 240 VAC
- C = Pulse DC for SSR drive: 14 VDC (40 mA max)
- 9 = Other

Output 2 BOX 4

For TEC-410

- 0 = None
- 1 = Relay: 2A / 240VAC, Form C
- 2 = Pulse DC for SSR drive – 5VDC (30mA max)
- 6 = Triac-SSR output 1A / 240VAC
- 7 = Isolated 20V @ 25mA DC, Output Power Supply
- 8 = Isolated 12V @ 40mA DC, Output Power Supply
- 9 = Isolated 5V @ 80mA DC, Output Power Supply
- C = Pulsed voltage to drive SSR, 14V/40mA

For TEC-910

- 0 = None
- 1 = Form A Relay: 2A / 240 VAC
- 2 = Pulse voltage to drive SSR drive, 5V/30mA
- 6 = Triac Output 1A / 240VAC, SSR
- 7 = Isolated 20V @ 25mA DC Output Power Supply
- 8 = Isolated 12V @ 40mA DC Output Power Supply
- 9 = Isolated 5V @ 80mA DC Output Power Supply
- A = RS-485
- B = Event Input
- C = Pulsed voltage to drive SSR, 14V/40mA
- D = Retransmit 4-20mA/0-20mA
- E = Retransmit 1-5V/0-5V
- F = Retransmit 0-10V
- H = Special order

Communications BOX 5 (TEC-410 only)

- 0 = None
- 1 = RS-485 Interface
- 2 = RS-232 Interface
- 3 = Retransmission 4-20 mA, 0-20 mA
- 4 = Retransmission 1-5 VDC, 0-5 VDC
- 5 = Retransmission 0-10 VDC
- 9 = Other

Mounting Option BOX 6 (TEC-410 only)

- 0 = Standard Mounting, IP50
- 1 = NEMA 4X/IP65

Ordering Information

Model TEC-410 and TEC-910 are offered with the options listed in the worksheet above. Create an ordering code by filling in the boxes with the appropriate number and/or letter designation for your requirements and a part number will be assigned, or choose from the part numbers listed.

Standard lead time is stock to 2 weeks.



Note: Detailed information on features common to digital microprocessor-based TEC temperature controls and the complete Table of Input Range and Accuracy can be found on page 13-46.



Models TEC-410 & TEC-910 Specifications

Power Input

Standard: (TEC-410) 90-250 VAC, 47-63 Hz, 10 VA, 5W maximum
(TEC-910) 90-264 VAC, 47-63 Hz, 10 VA, 5W maximum

Optional: 11-26 VAC / VDC, 10 VA, 5W maximum

Signal Input

Resolution: 18 bits **Sampling Rate:** 5 samples / second

Accuracy: $\pm 0.24\%$ of span typical

Maximum Rating: -2 VDC minimum, 12 VDC maximum (1 minute for mA input)

Temperature Effect: $\pm 1.5 \mu\text{V} / ^\circ\text{C}$ for all inputs except mA input
 $\pm 3.0 \mu\text{V} / ^\circ\text{C}$ for mA input

Sensor Lead Resistance Effect: T/C: $0.2 \mu\text{V}/\text{ohm}$
3-wire RTD: $2.6^\circ\text{C}/\text{ohm}$ of resistance difference of two leads

Burn-out Current: 200nA

Common Mode Rejection Ratio (CMRR): 120 dB

Normal Mode Rejection Ratio (NMRR): 55 dB

Sensor Break Detection: Sensor open for TC, RTD and mV inputs; sensor short for RTD input; below 1 mA for 4-20 mA input; below 0.25V for 1-5V input; unavailable for other inputs

Sensor Break Response Time: Within 4 seconds for TC, RTD and mV inputs; 0.1 second for 4-20 mA and 1-5 V inputs

Output 1 / Output 2

Relay Rating: 240 VAC, 2 Amp

Pulsed Voltage: Source voltage 5V, Current limiting resistance 66 Ω

Solid State Relay (Triac) Output

Rating: 1A / 240 VAC **Inrush Current:** 20A for 1 cycle

Min. Load Current: 50 mA rms

Max. Off-state Leakage: 3 mA rms

Max. On-state Voltage: 1.5 VAC rms

Insulation Resistance: 1000 Megohms minimum at 500 VDC

Dielectric Strength: 2500 VAC for 1 minute

VDC Voltage Supply (Output 2 only)

20 VDC, $\pm 0.5\text{V}$, at 25 mA

12 VDC, $\pm 0.3\text{V}$, at 40 mA

5 VDC, $\pm 0.15\text{V}$, at 80 mA

Event Input (standard TEC-410, optional TEC-910)

Resolution: 18 bits

Logic Low: -10 VDC minimum, 0.8 VDC maximum

Logic High: 2 VDC minimum, 10 VDC maximum

Functions: Remote reset, remote lockout

TEC-410 Stock and Common Part Numbers (Power Input: 90-250 VAC)

| Part Number | Signal Input | Out 1 | Out 2 |
|-------------|--------------|------------|-------|
| TEC51001 | tc | relay | none |
| TEC51002 | tc | relay | relay |
| TEC51003 | tc | 5VDC pulse | none |
| TEC51004 | tc | 5VDC pulse | relay |
| TEC51005 | tc | SSR-1A | none |
| TEC51006 | tc | SSR-1A | relay |

TEC-910 Stock and Common Part Numbers (Power Input: 90-264 VAC)

| Part Number | Signal Input | Out 1 | Prog. I/O |
|-------------|--------------|----------|-------------|
| TEC16001 | tc | relay | event input |
| TEC16002 | tc | DC pulse | event input |
| TEC16003 | tc | SSR-1A | event input |
| TEC16004 | tc | relay | none |
| TEC16005 | tc | DC pulse | none |
| TEC16006 | tc | SSR-1A | none |

NOTE: See page 13-46 for features common to TEC digital microprocessor-based temperature controls and the complete Table of Input Range and Accuracy.

Limit Control

Modes available: High Limit, Low Limit and High/Low Limit

Data Communications

Interface: RS-485 (up to 247 units), RS-232, *TEC-410 only*

Protocol: Modbus Protocol – RTU mode

Address: 1-247

Baud Rate: 0.3 - 38.4 Kbits/sec

Data Bits: 8 bits

Parity Bit: None, Even or Odd

Stop Bit: 1 or 2 bits

Communication Buffer: 50 bytes

User Interface

Single 4-digit LED Displays: 0.4" / 10 mm

Keypad: 4 keys

Programming Port: For automatic setup, calibration and testing

Environmental and Physical

Operating Temperature: 14 to 122°F (-10 to 50°C)

Humidity: 0 to 90% RH, non-condensing

Dielectric Strength: 2000 VAC, 50/60 Hz for 1 minute

Dimensions:

TEC-410: 3-3/4 × 3-3/4 × 2-9/16" (96 × 96 × 65 mm) H×W×D

Depth behind panel: 2" (53 mm)

Panel Cutout: 3-21/32" × 3-21/32" (93 × 93 mm) H×W

Weight: 0.55 lb. (250 grams)

TEC-910: 1-7/8 × 1-7/8 × 3-3/4" (48 × 48 × 94 mm) H×W×D

Depth behind panel: 3-3/8" (86 mm)

Panel Cutout: 1-25/32" × 1-25/32" (45 × 45 mm) H×W

Weight: 0.33 lb. (150 grams)

Approval Standards

Safety: FM Class 3545 (OCT. 1998)

CSA: C22.2 No. 24-93

EN61010-1 (IEC1010-1)

TEC-410: UL61010C-1

TEC-910: UL873

Protective Class: IP30 front panel, indoor use,
IP20 housing and terminals (with protective cover)

EMC: EN61326

TEC-410 1/4 DIN Rear Terminal Connections

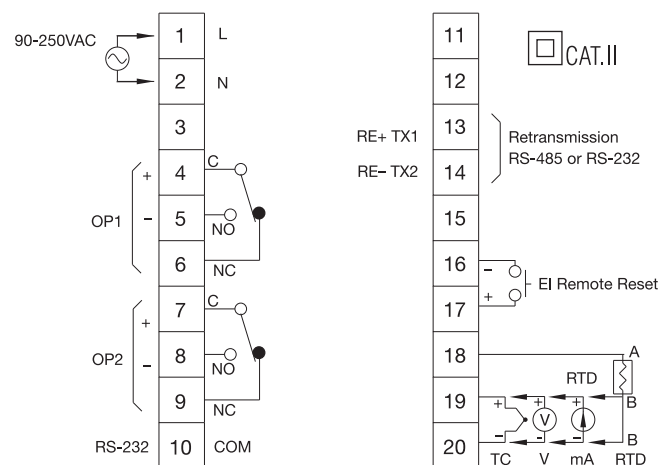

TEC-910 1/16 DIN Rear Terminal Connections

